

## PLAIN BODY

Welding black-oxide steel.

## PLUNGER

Black-oxide steel with hardened end.

Suggested tolerance for matching hole = G7.

## KNOB

High-resilience polyamide based (PA) technopolymer, black colour, matte finish.

## STANDARD EXECUTIONS

- **GN 618-A:** with knob.
- **GN 618-G:** without knob.

## FEATURES AND APPLICATIONS

GN 618 indexing plungers are especially designed for assembly by means of welding.



GN 618-A

GN 618-G

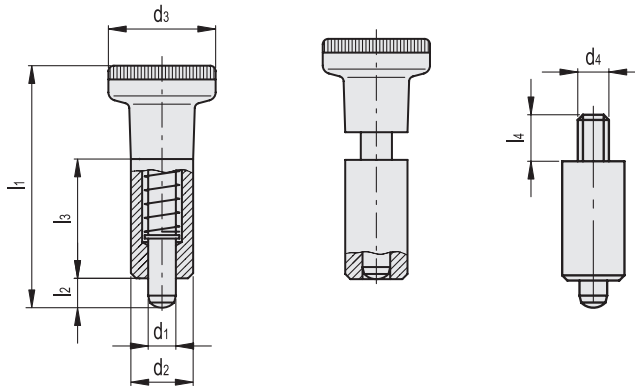

Conversion Table 1 mm = 0.039 inch	
D1	
mm	inch
5	0.20
6	0.24
8	0.31

Code	Description	d1 Plunger -0.02-0.04 Hole H7	d2 h9	d3	d4	l1	l2	l3	l4	Spring preload [N]	Spring max load [N]	⚖️
GN.36101	GN 618-5-A	5	12	21	-	45	5	22	-	7	17	30
GN.36111	GN 618-6-A	6	14	25	-	54.5	6	26	-	9	24	44
GN.36121	GN 618-8-A	8	18	31	-	69	8	34	-	12	30	44
GN.36102	GN 618-5-G	5	12	21	M5	45	5	22	6	7	17	25
GN.36112	GN 618-6-G	6	14	25	M6	54.5	6	26	10	9	24	37
GN.36122	GN 618-8-G	8	18	31	M8	69	8	34	12	12	30	73